

**CAMBRIDGE INTERNATIONAL EXAMINATIONS**

Cambridge International General Certificate of Secondary Education

## **MARK SCHEME for the October/November 2015 series**

### **0653 COMBINED SCIENCE**

**0653/21**

Paper 2 (Core Theory), maximum raw mark 80

This mark scheme is published as an aid to teachers and candidates, to indicate the requirements of the examination. It shows the basis on which Examiners were instructed to award marks. It does not indicate the details of the discussions that took place at an Examiners' meeting before marking began, which would have considered the acceptability of alternative answers.

Mark schemes should be read in conjunction with the question paper and the Principal Examiner Report for Teachers.

Cambridge will not enter into discussions about these mark schemes.

Cambridge is publishing the mark schemes for the October/November 2015 series for most Cambridge IGCSE<sup>®</sup>, Cambridge International A and AS Level components and some Cambridge O Level components.

© IGCSE is the registered trademark of Cambridge International Examinations.

Page 2	Mark Scheme	Syllabus	Paper
	Cambridge IGCSE – October/November 2015	0653	21

- 1 (a) (i) **B and D** ; [1]
- (ii) **C** ; [1]
- (b) (on either cell **B** or **D** or a mixture of both) correct labelling of:  
 cell wall ;  
 vacuole ;  
 chloroplast ; [max 2]
- (c) (i) shape **X**, **AND**  
 lost less water (by transpiration) ;  
 this leaf / shoot has smaller (total) surface area ; [2]
- (ii) (*temperature*) (distance increases as) rate of transpiration increases / more  
 water lost in warmer conditions ;  
 (*humidity*) (distance increases as) rate of transpiration increases / more water  
 lost with reduced humidity ; [2]
- [Total: 8]**
- 2 (a) increases ; [1]
- (b) sodium atoms lose electrons ;  
 bromine atoms gain electrons ; [2]
- (c) (i) bromine ; [1]
- (ii) chlorine + sodium bromide → bromine + sodium chloride  
 LHS ; RHS ; [2]
- (iii) chlorine displaces bromine but iodine does not displace bromine ;  
 a more reactive halogen displaces a less reactive halogen / owtte ;  
**OR**  
 chlorine more reactive than bromine and so displaces it ;  
 iodine less reactive than bromine so does not displace it ; [max 2]
- [Total: 8]**
- 3 (a) potential (energy) **to** kinetic (energy) ; [1]
- (b) (i) weight / gravitational force ; [1]
- (ii) arrow on Fig. 3.1 pointing upwards ; [1]
- (iii) newton ; [1]

(c)

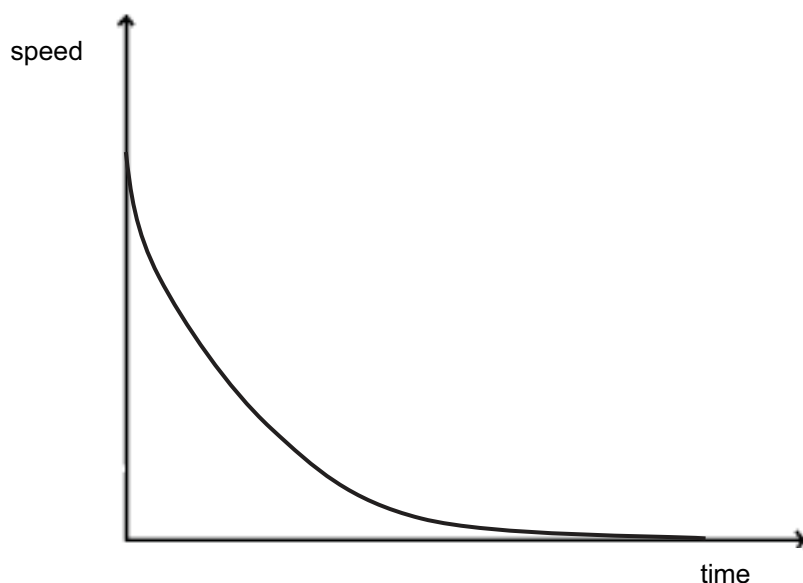

straight line/curve from higher on the y-axis with negative gradient ;  
line intersects x-axis ;

[2]

(d) any estimate less than 40 m, greater than 25 m ;  
weight of man stretching rope ;

[2]

(e) (KE causes) friction in the rope as it stretches and slackens/owtte ;

[1]

**[Total: 9]**

4 (a) (i) urethra correctly labelled ;  
prostate gland correctly labelled ;

[2]

(ii) yes, **AND**  
the sperm duct/tube ;  
on the unblocked/other side is clear ;  
idea of clear route for sperms (from testis) ;  
*allow:* idea of reduced fertility ;

[max 3]

(b) (i) days 0–5/6/7 and/or 30–35/36/37 ;  
lining of uterus is being shed/breaking down ;

[2]

(ii) day 14/15/16 ;

[1]

(iii) controlled by hormones/controlled by ovaries ;

[1]

(iv) for implantation/nourishment of embryo/ball of cells ;

[1]

**[Total: 10]**

5 (a) natural gas / biogas ; [1]

(b) (i)

<i>gases present <b>before</b> the explosion</i>	➔	<i>gases present <b>just after</b> the explosion</i>
(methane)		carbon dioxide
(oxygen)		water (vapour)
(nitrogen)		nitrogen

(all 3 correct for 2 marks, 2 correct for 1 mark)

::

[2]

(ii) exothermic ;

[1]

(c) (i)  $C_9H_{20}$  ;

[1]

(ii) covalent ;  
bonding between non-metals / electron sharing ;

[2]

(d) (i) condenses ;

[1]

(ii) different boiling points ;

[1]

[Total: 9]

6 (a)

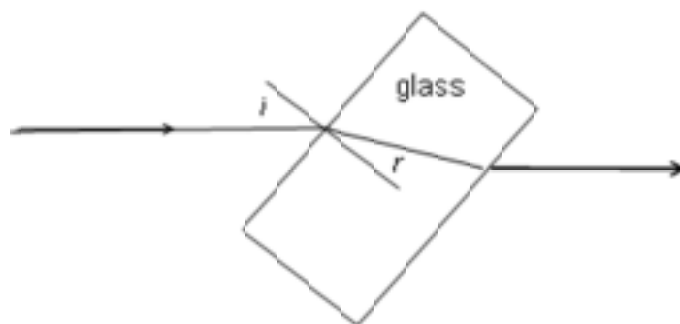

ray in glass bent towards normal ;  
emergent ray parallel to incident ;  
*i* and *r* clearly marked for correct angles ;

[3]

- (b) (i) ultra-violet/X-rays/gamma radiation ; [1]  
(ii) infra-red/IR ; [1]
- (c) (i) wavelength shown correctly and clearly ;  
amplitude shown correctly and clearly from x-axis to peak ; [2]  
(ii) loudness / volume ; [1]

**[Total: 8]**

7 (a)

<i>component of blood</i>	<i>function</i>
plasma	transport of oxygen
platelets	clotting of blood
red blood cells	defence against disease
white blood cells	transport of dissolved substances

(all correct for 2 marks, 2 or 1 correct for 1 mark)

;;

- (b) (i) diffusion happens from a higher to a lower concentration ; [1]  
(ii) used to react / break down glucose ;  
during respiration ; [2]  
(iii) any flight / fight / fear situation described ; [1]  
(iv) increase in pulse rate ;  
increase in blood glucose ;  
AVP ; [max 2]

**[Total: 8]**



<b>Page 6</b>	<b>Mark Scheme</b>	<b>Syllabus</b>	<b>Paper</b>
	<b>Cambridge IGCSE – October/November 2015</b>	<b>0653</b>	<b>21</b>

- 8 (a) (i) flame/lighted splint ;  
explosion/‘pop’/burns with a squeaky pop ; [2]
- (ii) acid concentration decreases ;  
acid used up/not enough acid to react with all the iron ;  
rate of reaction decreases/reaction stops ; [max 2]
- (iii) silver nitrate ;  
white precipitate/owtte ; [2]
- (b) faster/more bubbling ;  
increase in temperature causes increase in rate of reaction/reaction finishes more quickly ; [2]
- (c) no reaction/bubbles ;  
copper is below hydrogen in the reactivity series/owtte ; [2]

**[Total: 10]**

- 9 (a) (i) potential difference/p.d. ; [1]
- (ii) current increases/goes up ; [1]
- (iii) meter reading increases/goes up ;  
current increases/goes up ;  
resistance decreases/goes down in a parallel circuit ; [max 2]
- (iv)  $(4 \times 2) = 8 (\Omega)$  ; [1]

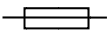
(b)

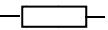
<i>circuit component</i>	<i>symbol</i>
<i>direct current source</i>	
<i>fuse</i>	
<b>lamp / bulb</b>	
<i>fixed resistor</i>	

(all correct for 2 marks, 2 or 1 correct for 1 mark) [2]

<b>Page 7</b>	<b>Mark Scheme</b>	<b>Syllabus</b>	<b>Paper</b>
	<b>Cambridge IGCSE – October/November 2015</b>	<b>0653</b>	<b>21</b>

(c) (i) convection ; [1]

(ii) description / diagram of suitable apparatus ; [2]  
description of observation made that shows convection ;

**[Total: 10]**